

Lifting station Aqualift S 100 Duo, GTF 1250, Free-standing set-up

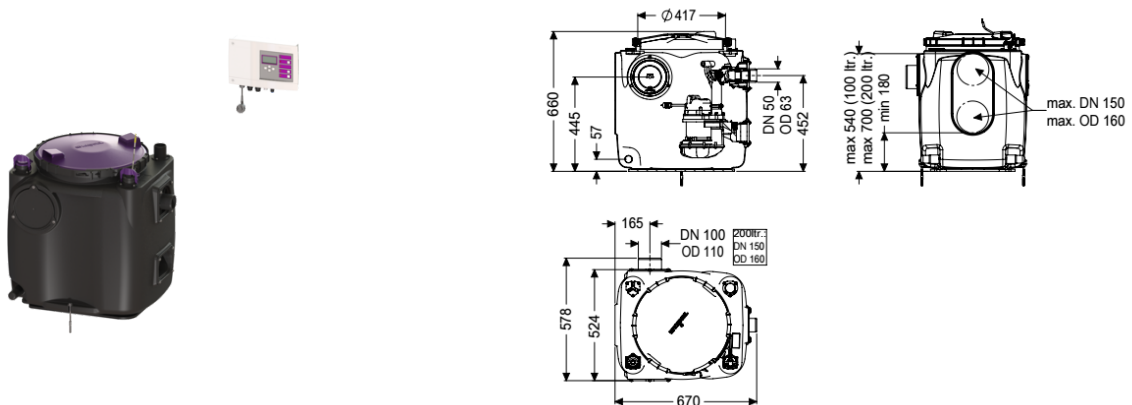

Article information

Item no.: 28516
 GTIN: 4026092092927
 Price group: 20

Advantages

- Easy tool-free maintenance
- Tank made of PE, resistant to aggressive wastewater
- Including backflow preventer for the pressure pipe

Description

The ready to plug in lifting station for faecal-free wastewater is equipped with one or two submersible pumps and a backflow preventer. The collection tank made of permanently resistant polymer (PE) has an open pump tank. One-handed closures enable easy removal of the integrated components.

Variant

| | |
|---------------------|--------------|
| Type of system: | duo pump |
| Pump control: | Control unit |
| Backflow preventer: | integrated |
| Sampling device: | integrated |

General characteristics

| | |
|-------------------------|--|
| Colour: | black |
| Standard: | EN 12050-2 |
| Type of wastewater: | without sewage |
| Installation situation: | free-standing installation |
| Delivery state: | Pre-mounted for final assembly on site (pumps and sensor system must be fitted on site and control unit must be connected) |
| System type: | Duo |

Dimensions

| | |
|-------------|---------|
| Net weight: | 45,8 kg |
|-------------|---------|

| | |
|--|--------------------------------|
| Gross weight: | 45,8 kg |
| Length: | 670 mm |
| Width: | 530 mm |
| Height: | 650 mm |
| Packaging dimension: | length |
| Packaging dimension: | width |
| Packaging dimension: | height |
| Tank/drain body | |
| Pressure pipe connection (DN): | 50 |
| Pressure pipe connection (OD): | 63 mm |
| Inlet nominal size (DN): | 100 mm |
| Pumping volume: | 50 l |
| Tank volume: | 120 l |
| Coverage features | |
| Type of cover: | Cover |
| Cover material: | Polymer |
| Colour of cover: | violet |
| Locking: | Quick-release closure |
| Tightness: | odour-tight |
| Pumping device | |
| Pump: | GTF 1250 |
| Number of pumps: | 2 |
| Weight, pump: | 10 kg |
| Connection type: | coded plug |
| Rated current: | 5,4 A |
| Length of mains cable for pump: | 5 m |
| Protection class: | I |
| Insulation class: | F |
| Protection class (pump): | IP 68 (3m) |
| Temperature monitoring: | integrated |
| Max. temperature (permanent) of conveyed material: | 40 °C |
| Max. pumping capacity: | 20 m ³ /h |
| Max. pumping height: | 11 m |
| Speed: | 2700 U/min |
| Power P1: | 1,3 kW |
| Power P2: | 0,8 kW |
| Operating mode: | S1 |
| Type of fuse required (electrical protection): | C 16 A |
| Type of pump connection cable: | H07RN-F 3G 1.5 mm ² |
| Impeller type: | Multi-vane impeller |
| Free passage: | 30 mm |
| Control | |
| Control unit: | Comfort |
| Control unit function: | With alarm message |
| Motor protection switch: | yes |

| | |
|---|-----------------------------|
| Level measurement instrument: | Immersion pipe |
| Type of level measurement: | pneumatic |
| Protection class control unit: | IP 54 |
| Mains frequency: | 50 Hz |
| Operating voltage: | 230 V |
| Connection type: | coded plug |
| Length of mains cable for control unit: | 1,4 m |
| Potential-free contact: | optional |
| GSM interface: | yes |
| USB interface: | yes |
| Log book function: | yes |
| Multi-line display: | yes |
| Battery buffering: | yes |
| Self-diagnosis system (SDS): | yes |
| Warning equipment version: | acoustic and optical signal |
| Rated current: | 5,4 A |